

PRESSURE INDICATOR

REX-PG410

INSTRUCTION MANUAL

IM41PG01-E2

Before using this product, please carefully read this manual for its correct use. In addition, after reading the manual keep it available easily anytime.

- This manual is subject to change without prior notice.
- This manual may not be reproduced or copied in whole or in part without RKC's prior consent.
- This manual and the REX-PG410 manufactured, prepared, then shipped under strict quality control. However, if any defect is found, please contact your nearest RKC sales office or agent from which you bought the product.
- RKC assume no responsibility for any of the following damage which the user or third party may suffer.
 - ① Damages incurred as result of using this product.
 - ② Damages caused by product failure which can not be predicted by RKC.
 - ③ Other indirect damages.

▶ MARKING CAUTIONS ◀

For safe operation of "REX-PG410", the following "Signal Words and Symbol Marks" are used in this manual.

<Signal Words>

WARNING :

Where there are possible dangers such as electric shock, fire (burns), etc. which could cause loss of life or injury, precautions to avoid such dangers are described.

CAUTION :

These describe precautions to be taken if unit damage may result if operating procedures are not strictly followed.

NOTE :

Extra notes or precautions are added to operating procedures and explanations.

<Symbol Marks>

-  : This mark is used when great care is needed especially for safety.
- *** : This mark is used to add extra notes, precautions or supplementary explanations to table and figures.

▶ OPERATION PRECAUTIONS ◀

- Before cleaning the instrument, check that the power is turned off.
- Remove stains on the display unit using a soft cloth or tissue paper.
- As the display unit is easily scratched, do not scrub or touch it with a hard object.
- Do not operate the front key with a pointed object such as a ball point pen or screwdriver, as this may scratch or damage the key.

WARNING

● Wiring precautions

- If failure or error of this instrument could result in a critical accident of the system, install an external protection circuit to prevent such an accident.
- In order to prevent instrument damage or failure, protect the power line and the input/output lines from high currents by using fuses with appropriate ratings.

WARNING

- **Power supply**
 - In order to prevent instrument damage or failure, supply power of the specified rating.
 - In order to prevent electric shock or instrument failure, do not turn on the power supply until all of the wiring is completed.
- **Never use the instrument near inflammable gases**
 - In order to prevent fire, explosion or instrument damage, never use this instrument at a location where inflammable or explosive gases or vapour exist.
- **Never touch the inside of the instrument.**
 - In order to prevent electric shock or burns, never touch the inside of the instrument. Only RKC service engineers can touch the inside of the instrument to check the circuit or to replace parts. High voltage and high temperature sections inside the instrument are extremely dangerous.
- **Never modify the instrument.**
 - In order to prevent accident or instrument failure, never modify the instrument.
- **Maintenance**
 - In order to prevent electric shock, burns or instrument failure, only RKC service engineers may replace parts.
 - In order to use this instrument continuously and safely, conduct periodic maintenance. Some parts used in this instrument have a limited service life and may deteriorate over time.

1. PRODUCT CHECK

Check whether the delivered product is as specified by referring to the following model code list.

■ Model code

REX-PG410 * -
① ② ③ ④ ⑤ ⑥

① Input type

- A : Pressure sensor (Standard specification)
- B : Pressure sensor (Explosion-proof construction specification)
- C : Pressure sensor [0 to 0.5 MPa (0 to 5 Kgf/cm²)] (Standard specification)
- D : Pressure sensor [0 to 0.5 MPa (0 to 5 Kgf/cm²)] (Explosion-proof construction specification)

② Power supply

- 3 : 24 V AC/DC
- 4 : 100 to 240 V AC

③ First Alarm [ALM1]

- N : No first alarm
- H : Process high alarm *1
- J : Process low alarm *1
- K : Process high alarm *2
- L : Process low alarm *2

④ Second Alarm [ALM1]

- N : No second alarm
- H : Process high alarm *1
- J : Process low alarm *1
- K : Process high alarm *2
- L : Process low alarm *2

⑤ Analog output

- N : No analog output
- M : 0 to 2 V DC
- 1 : 0 to 10 mV DC
- 4 : 0 to 5 V DC
- 5 : 0 to 10 V DC
- 6 : 1 to 5 V DC
- 7 : 0 to 20 mA DC
- 8 : 4 to 20 mA DC

⑥ Communication function

- N : No communication function
- 4 : RS-422 A (4-wire system)
- 5 : RS-485 (2-wire system)

- *1 : Without hold action
- *2 : With hold action

◎ Confirm that power voltage is also the same as that specified when ordering.

Accessories

- Mounting brackets (2 pcs.)
- Instruction manual [IM41PG01-E2] (1 copy)

2. MOUNTING



WARNING

- In order to prevent electric shock, or instrument failure, do not turn on the power supply until all of the wiring of the completed.

■ Cautions for mounting ⚠

Avoid the following when selecting the mounting location.

- Ambient temperature of less than 0 °C (32 °F) or more than 50 °C (122 °F).
- Ambient humidity of less than 45% or more than 85% RH.
- Rapid changes in ambient temperature which may cause condensation.
- Corrosive or inflammable gases.
- Direct vibration or shock to the mainframe.
- Water, oil, chemicals, vapor or steam splashes.
- Excessive dust, salt or iron particles.
- Excessive induction noise, static electricity, magnetic fields or noise.
- Direct air flow from an air conditioner.
- Should be used indoors where the system is not exposed to direct sunlight.
- Heat to be accumulated radiation heat.

■ Dimensions

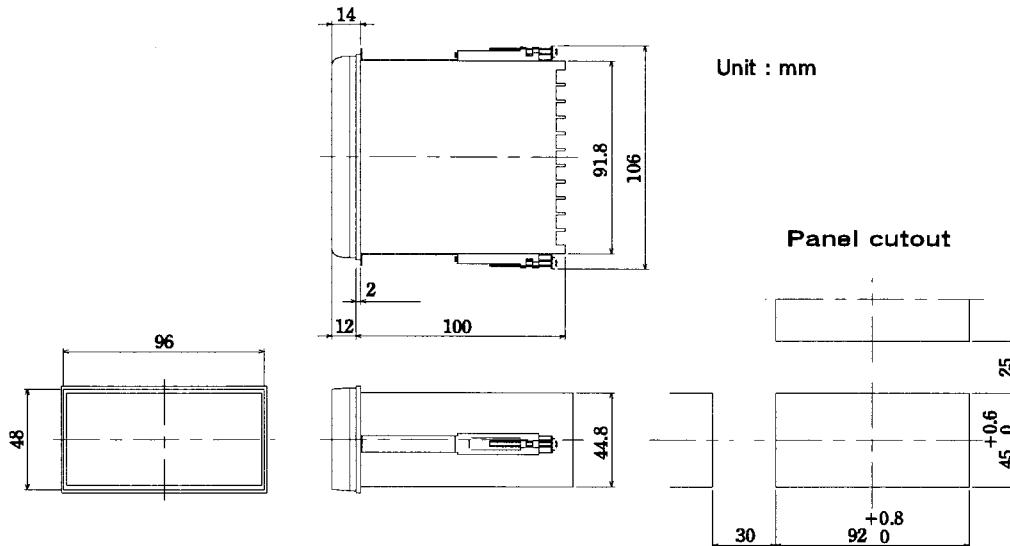

■ Mounting procedures

- ① Make a rectangular cutout corresponding to the number of controllers to be mounted on panel by referring to the panel cutout dimensions.
- ② Insert the controllers into the panel from the panel front.
- ③ Insert an upper mounting bracket along the bracket insertion groove from the back, and then engage a projection at the bracket end with a recess at the groove front and also insert metal fitting legs into slots.
- ④ Tighten a bracket setscrew from the rear of the bracket with Phillips screwdriver. Do not overtighten the bracket setscrew. [Recommended tighten torque : 0.3 N·m or less (3 kgf·cm or less)]
- ⑤ Set the other mounting bracket in the same way as in ③ and ④.

* This instrument is provided with a waterproof and dustproof rubber packing.
For details of replacing the packing due to deterioration, see " 8. Replacing the waterproof and dustproof rubber packing ".

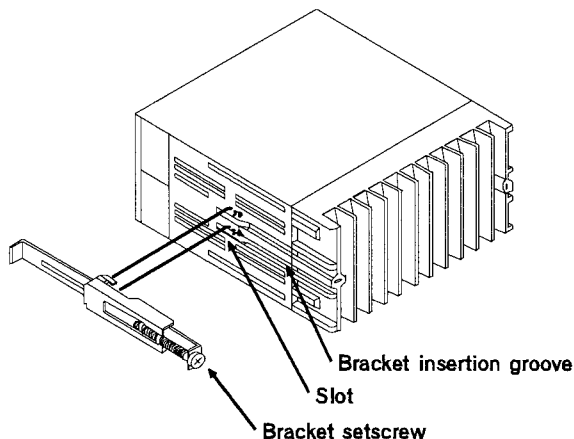

NOTE

The front of this instrument conforms to IP54 with the instrument mounted on a control panel.

3. WIRING



WARNING

- In order to prevent electric shock, or instrument failure, do not turn on the power supply until all of the wiring of the completed.
- If failure or error of this instrument could result a critical accident of the system, install an external protection circuit to prevent such an accident.
- In order to prevent instrument damage or failure, protect power line and the input/output lines from right current by using fuses with appropriate ratings.

■ Cautions for wiring ⚠

- (1) The sensor connect to the REX-PG410 using the 4-core shielded cable attached.
The rated output of the sensor (mV/V : Described on the nameplate adhered) is obtained when standard-cable length is 5 m.
If the cable is extended, correct the rated output using the following equation, if necessary.
[Example: a cable extension of 50 m results in an indication fall of 1 % FS.]
If the rated output is corrected using the following equation, set this corrected value to the gain.

$$e_1 = e_2(1 + K \cdot \ell) \quad \longrightarrow \quad e_2 = e_1 / (1 + K \cdot \ell)$$

- Where e_1 : Rated output in standard-cable length of 5 m
(mV/V : Described on the nameplate adhered)
- e_2 : Rated output after cable extension
- K : Correction factor $1.96 \times 10^{-4}/\text{m}$
(When $0.5 \text{ mm}^2 \times 4$ -core shielded cable is used.)
Same as standard cable
- ℓ : Extended cable length(m)

CAUTION

For the explosion-proof specification, K becomes $1.4 \times 10^{-4}/\text{m}$, and thus a cable extension of 50 m results in an indication fall of 0.1 % FS.

- (2) Conduct input signal wiring away from instrument power, electric equipment power and load lines as such as possible to avoid noise induction.
- (3) Conduct instrument power wiring so as not to be influenced by noise from the electric equipment power. If it is assumed that a noise generation source is located near the controller and the controller is influenced by noise, use a noise filter.
- ① To obtain a satisfactory noise filter effect, select the most suitable type after due consideration of instrument power supply voltage and filter frequency characteristics.
 - ② For instrument power wiring, if it is assumed that noise exerts a bad influence upon the controller, shorten the distance between twisted power supply wire pitches. (The shorter the distance between the pitches, the more effective for noise reduction.)
 - ③ Install the noise filter on the panel which is always grounded and minimize the wiring distance between the noise filter output side and the instrument power terminals. Otherwise, the longer the distance wiring, the less effective for noise.
 - ④ Do not install fuses and/or switches on the filter output signal since this may lessen filter effect.
- (4) For wiring, use wires conforming to the domestic standard of each country.
· Use power supply wires, use 600 V Polyvinyl chloride insulated wires (JIS C3307).
- (5) About 5 to 6 sec. are required as the preparation time of contact output during power-ON.
Use a delay relay when the output line, is used for an external interlock circuit.
- (6) When connecting wires, note that the power, input/MCU and output circuits are isolated independently, while the inside of the input and output circuits are not isolated.
- (7) This instrument has no power supply switch nor fuses. Therefore, install the fuse close to the instrument and the switch, if required.
[Recommended fuse rating : Rated voltage ; 250 V Rated current ; 1 A Type ; Time-lag fuse]
- (8) This instrument is intended to be used under the following environmental conditions. (IEC1010)
[OVERVOLTAGE CATEGORY II, POLLUTION DEGREE 2]

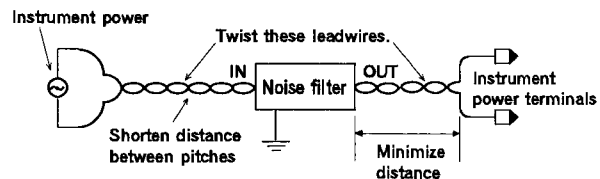

Terminal configuration

Continuous voltage/current output

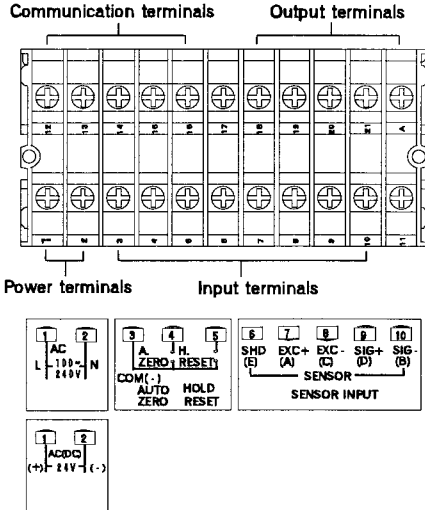
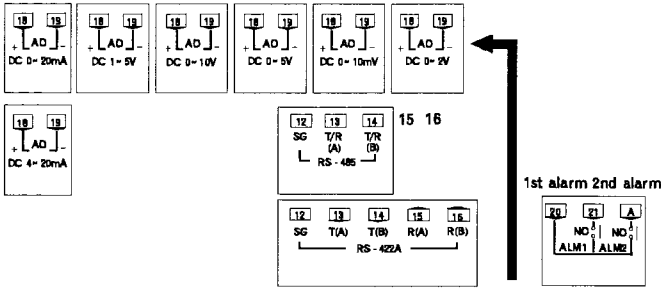

- Alarm output rated
Relay contact output 250 VAC, 0.5 A (Resistive load)
- Analog output
0 to 2 V DC (Load resistance 40k Ω or more)
0 to 10 mV DC (Load resistance 20k Ω or more)
0 to 5 V DC (Load resistance 1k Ω or more)
0 to 10 V DC (Load resistance 1k Ω or more)
1 to 5 V DC (Load resistance 1k Ω or more)
0 to 20 mA DC (Load resistance 600 Ω or less)
4 to 20 mA DC (Load resistance 600 Ω or less)

- Crimp-style terminal lug
Therefore, use the lug suitable for a screw of M3.

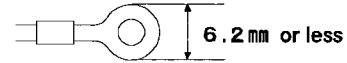

- Recommended tighten torque : 0.4 N·m (4 kgf·cm)
[Maximum allowance tighten torque :
1.0 N·m (10 kgf·cm)]

NOTE Terminals which are not used according to the controller type are all removed.

Wiring example

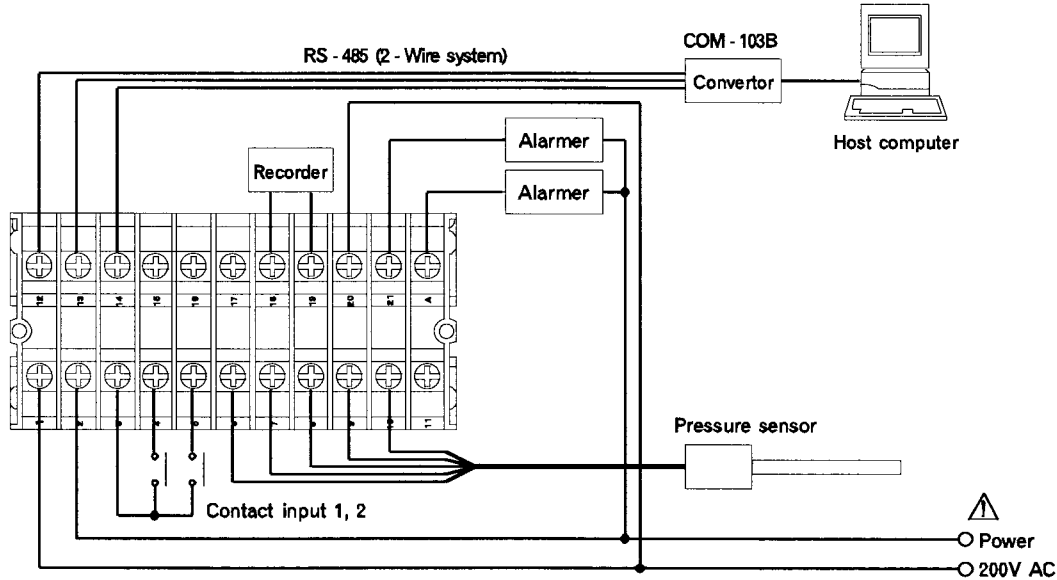

4. NAME OF PARTS

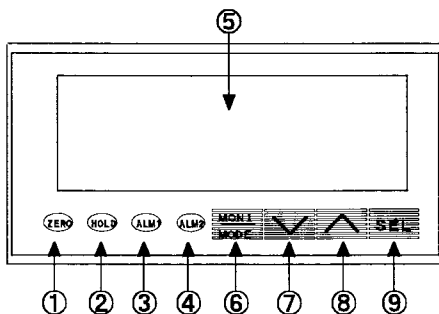

- ① AUTO ZERO lamp (Green)
- ② HOLD RESET lamp (Green)
- ③ First alarm (ALM1) lamp (Red)
- ④ Second alarm (ALM2) lamp (Red)
- ⑤ Measured-value (PV) display unit (Red)
- ⑥ MONI/MODE key
- ⑦ Set-value decrement key
- ⑧ Set-value increment key
- ⑨ SEL key

5. OPERATION

5.1 Calling procedure in each mode

Broadly, the following six statuses are available for this instrument.

- PV display mode : Displays measured-value (PV)
- Operator mode : Mode to confirm peak hold value/bottom hold value
- Operator set mode : Mode to execute auto-zero, to reset hold, to release interlock or to change alarm set-value
- Engineer mode : Mode to lock setting
- Engineer set mode : Mode to set or confirm various parameters
- SETUP set mode* : Mode to select input or output function

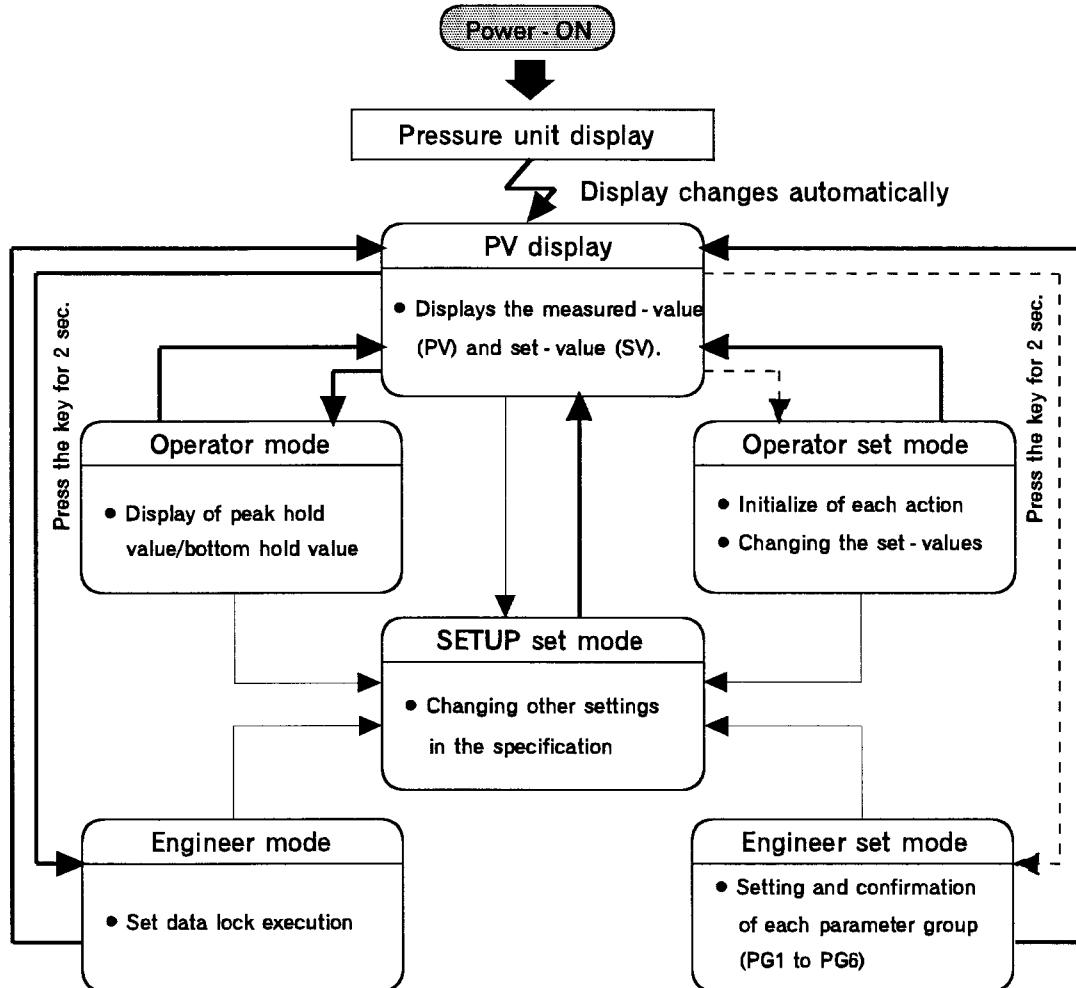

→ : Press the **MONI/MODE** key. --> : Press the **SEL** key. → : Press the **MONI/MODE** and **SEL** keys simultaneously.

* The SETUP set mode accesses parameters which are not usually changed.

■ Pressure unit display

For this instrument, the pressure unit can be confirmed just after the power is turned on.

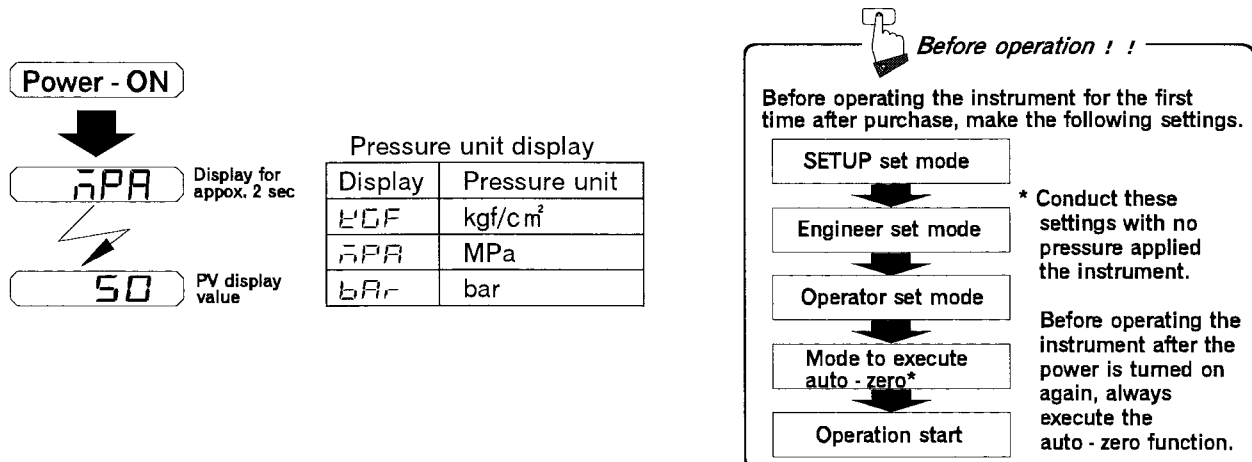

5.2 SETUP set mode

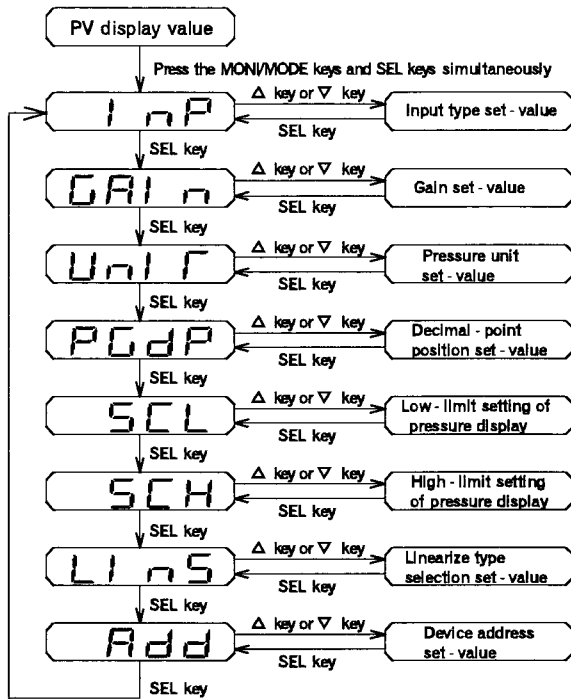

Symbol	Name	Setting range	Description	Initial value prior to shipment
InP (InP)	Input type selection	See *1	Selects the input type.	To be specified when ordering
GAI n (GAI n)	Gain setting	See *2	Set the gain to the rated output engraved on the sensor.	To be specified when ordering
UnI T (UnIT)	Pressure unit setting	0 : kgf/cm ² 1 : MPa 2 : bar	Set the pressure unit.	0
PGdP (PGdP)	Decimal-point position selection	0 : No digit below decimal-point 1 : 1 digit below decimal-point 2 : 2 digit below decimal-point 3 : 3 digit below decimal-point	Sets the decimal-point position on the voltage/current input scale.	0
SCL (SCL)	Low-limit setting of pressure display	0 to high-limit of pressure display	Sets the low-limit in the pressure display range.	0
SCH (SCH)	High-limit setting of pressure display	Low-limit of pressure display to 2000	Sets the high-limit in the pressure display range.	500
LI n S (LI n S)	Linearize type selection	0 to 20	Select and then set the linearize type matching the type of output characteristic of the pressure sensor. (For details of the setting procedure, see P.7.)	0
*3 Add (Add)	Device address	0 to 99	Sets the communication device address of this controller.	0

- *1 0 : Pressure sensor (Standard specification)
 1 : Pressure sensor (Explosion-proof construction specification)
 2 : Pressure sensor [0 to 0.5 MPa (0 to 5 Kg/cm²)
 (Standard specification)
 3 : Pressure sensor [0 to 0.5 MPa (0 to 5 Kg/cm²)
 (Explosion-proof construction specification)

- *2 When the input type is set to 0 or 1 : 1.000 to 1.800 mV/V
 When the input type is set to 2 or 3 : 0.500 to 0.800 mV/V

- *3 No displayed when there is no communication function.

⚠ Key operational cautions

- For this instrument, even if the setting is changed, it is not registered. Pressing the  key after the setting is changed registers the setting approx. 1 sec later.
- This instrument returns to the PV display value if key operation is not performed for more than 1 minute.

■ Linearizing function setting

- ① Check the type of output characteristic engraved at the end of the rated output value on the rating nameplate attached to the outer chamber of the pressure sensor.

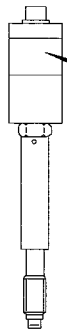

Pressure sensor

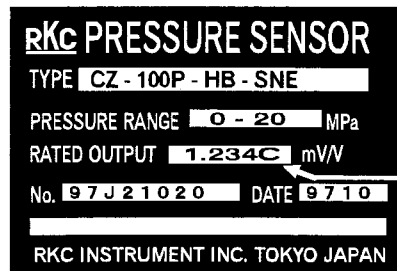

Rating nameplate (Example)

In this section, the type of output characteristic is engraved with the corresponding alphabetical letter. If not, the pressure sensor does not have the "Linearize function."

- ② Next, set the SETUP mode to "Linearize type selection (L I n S) ."
- (For details on calling up, see P.6.)
- ③ Press the Δ or ∇ key to enable the "Linearize type selection" setting to be changed.
- ④ Select the linearize type to match the type of output characteristic engraved on the rating nameplate of the pressure sensor from the following "Linearize type selection table", and then set it.

CAUTION

If the type of output characteristic is not engraved on the rating nameplate of the pressure sensor, always set "0." (Linearize function not provided)

● Linearize type selection table

Type of output characteristic	Linearize type set-value	Type of output characteristic	Linearize type set-value
Not engraved	0 (Function not provided)	M	10
		P	11
C	1	Q	12
D	2	R	13
E	3	S	14
F	4	T	15
G	5	U	16
H	6	V	17
J	7	W	18
K	8	X	19
L	9	Y	20

- ⑤ Press the **SEL** key after setting the numerical value to register the value, 1 sec later.

5.3 Operator mode

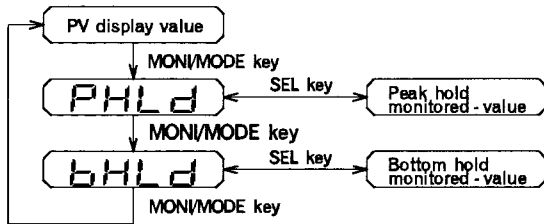

Peak hold value (PHLd) display

Displays the maximum pressure.

Display range : Low-limit of pressure display to High-limit of pressure display.

Bottom hold value (bHLd) display

Displays the minimum pressure.

Display range : Low-limit of pressure display to High-limit of pressure display.

5.4 Operator set mode

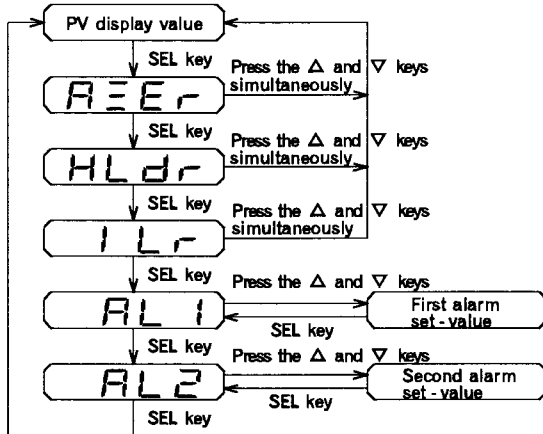

Symbol	Name	Setting range	Description	Initial value prior to shipment
AZEr (AZEr)	Auto-zero		Pressing the UP and DOWN keys simultaneously while the auto-zero characters are displayed executes the auto-zero function. After the auto-zero function is executed, the AUTO ZERO lamp lights for approx. 1 sec.	
HLdr (HLdr)	Hold reset		Simultaneously pressing the UP and DOWN keys while the hold reset characters are displayed executes the hold reset function. The HOLD RESET lamp light for approx. 1 sec after the hold reset function is executed.	
ILr (ILr)	Interlock release		Simultaneously pressing the UP and DOWN keys while the interlock release characters are displayed releases the alarm interlock function.	
AL1 (AL1)	First alarm set-value	Low-limit of pressure display to High-limit of pressure display.	Sets the alarm set-value of the first alarm. Pressing the SEL key after the set-value is changed by pressing the UP or DOWN key establishes the set-value.	500
AL2 (AL2)	Second alarm set-value	Low-limit of pressure display to High-limit of pressure display.	Sets the alarm set-value of the second alarm. Pressing the SEL key after the set-value is changed by pressing the UP or DOWN key establishes the set-value.	0

*1 Displayed when "Interlock function provided" is selected for the first or second alarm.

*2 Displayed when any item other than "No alarm provided" is selected for the first alarm.

*3 Displayed when any item other than "No alarm provided" is selected for the second alarm.

5.5 Engineer mode

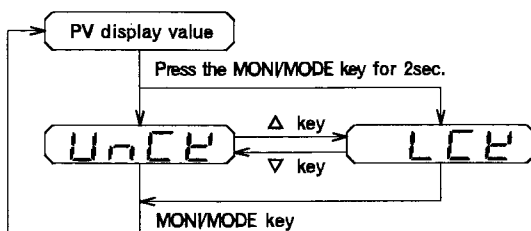

Set data unlock (Unck)/lock (Lck) transfer

Select whether the set data lock function is invalid (unlock) or valid.

* Any mode other than PV display, operator mode or engineer mode is not displayed when the set data is locked. In addition, after locking the set data, only the engineer mode can be changed.

5.6 Engineer set mode

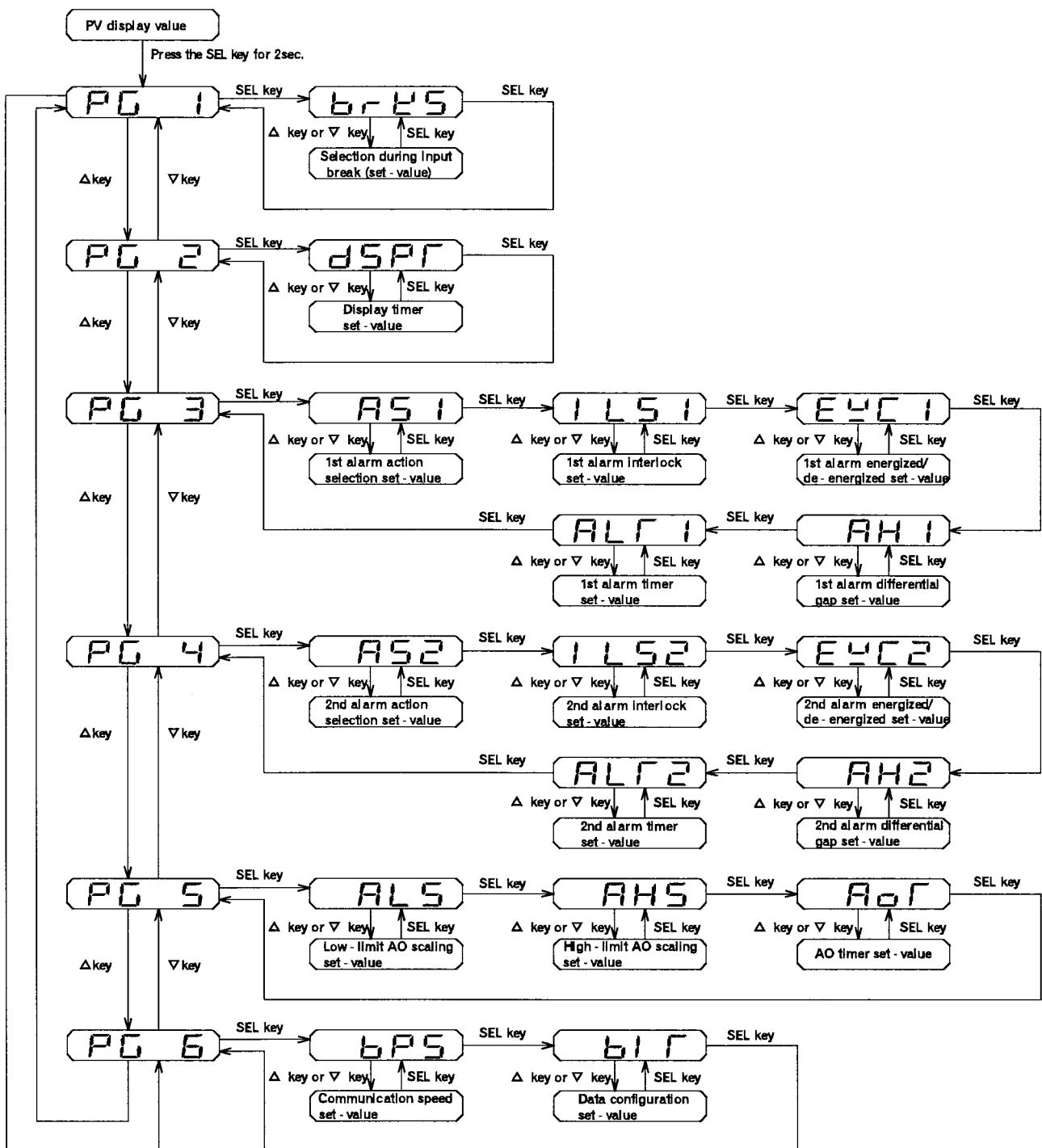

Symbol	Name	Setting range	Description	Initial value prior to shipment
PG 1 (PG1)	Parameter group 1		The first characters of parameter group (PG1). They are also displayed first when the instrument is set to engineer set mode	
brKS (brKS)	Selection during input break	0 : Upscale 1 : Downscale	Select upscale or downscale when the input is broken.	0
PG 2 (PG2)	Parameter group 2		The first characters of parameter group (PG2).	
dSPT (dSPT)	Display timer setting	0.1 to 10.0 sec	Sets the time during which the displayed value is changed.	0.1
PG 3 (PG3)	Parameter group 3		The first characters of parameter group (PG3).	

(Continued on the next page)

	Symbol	Name	Setting range	Description	Initial value prior to shipment
*3	AS1 (AS1)	First alarm action selection	See *1	Selects first alarm action.	To be specified when ordering
*3	ILS1 (ILS1)	First alarm interlock	0 : No interlock function provided 1 : Interlock function provided	Sets the presence or absence of the interlock function.	0
*3	EXC1 (EXC1)	First alarm energized/de-energized setting	0 : Energized action 1 : De-energized action	Selects whether first alarm is set to energized or de-energized.	0
*3	AH1 (AH1)	First alarm differential gap	0.0 to 10.0% of span	Sets first alarm differential gap.	2.0
*3	ALT1 (ALT1)	First alarm timer setting	0 to 600 sec	Sets time until alarm is turned ON after measured-value (PV) enters first alarm area.	0
	PG4 (PG4)	Parameter group 4		The first characters of parameter group (PG4).	
*4	AS2 (AS2)	Second alarm action selection	See *1	Selects second alarm action.	To be specified when ordering
*4	ILS2 (ILS2)	Second alarm interlock	0 : No interlock function provided 1 : Interlock function provided	Sets the presence or absence of the interlock function.	0
*4	EXC2 (EXC2)	Second alarm energized/de-energized setting	0 : Energized action 1 : De-energized action	Selects whether second alarm is set to energized or de-energized.	0
*4	AH2 (AH2)	Second alarm differential gap	0.0 to 10.0% of span	Sets second alarm differential gap.	2.0
*4	ALT2 (ALT2)	Second alarm timer setting	0 to 600 sec	Sets time until alarm is turned ON after measured-value (PV) enters second alarm area.	0
	PG5 (PG5)	Parameter group 5		The first characters of parameter group (PG5).	
*5	ALS (ALS)	Low-limit AO scaling set-value	Pressure display (low-limit) to AO scaling (high-limit)	Sets low-limit of the analog output range.	0
*5	AHS (AHS)	High-limit AO scaling set-value	AO scaling (low-limit) to pressure display (high-limit)	Sets high-limit of the analog output range.	500
*5	AoT (AoT)	AO timer setting	0.1 to 10.0 sec.	Sets the time during which the analog output is changed.	0.1
	PG6 (PG6)	Parameter group 6		The first characters of parameter group (PG6).	
*6	bPS (bPS)	Communication speed	0 : 1200bps 1 : 2400bps 2 : 4800bps 3 : 9600bps 4 : 19200bps	Selects communication speed.	3
*6	blT (blT)	Communication data bit configuration	See *2	Selects data bit configuration during communication.	0

*1 0 : Alarm OFF 1 : Process high alarm 2 : Process low alarm
3 : Process high alarm (with hold action) 4 : Process low alarm (with hold action)

Setting	Parity bit	Data bit [bit]	Stop bit [bit]
0	None	8	1
1	None	8	2
2	Even	7	1
3	Even	7	2
4	Odd	7	1
5	Odd	7	2

*3 Not displayed when there is no first alarm.
*4 Not displayed when there is no second alarm.
*5 Not displayed when there is no analog output.
*6 Not displayed when there is no communication function.

6. DESCRIPTION OF EACH FUNCTIONS

Auto-zero function

The sensor output matches the value on the indicator by automatically adjusting the zero point with no pressure applied to the sensor.

*The auto-zero function can be executed by contact input (terminal Nos. 3 and 4).

Display timer function

This function is used to update the PV displayed-value every time the display timer set time elapses.

Analog output timer function

This function is used to update the analog output value every time the analog output timer set time elapses.

Hold function

● Peak hold

When a PV value larger than the present PV value is input from the time the hold reset function is executed, this function is used to hold the former PV value.

● Bottom hold

When a PV value smaller than the present PV value is input from the time the hold reset function is executed, this function is used to hold the former PV value.

* Each hold action is activated from the time when the power is turned on.

* The hold reset function can be executed by contact input (terminal Nos. 3 and 5).

Alarm (ALM) function

Each alarm action is as follows. (Δ : Alarm setting)

● Process alarm function

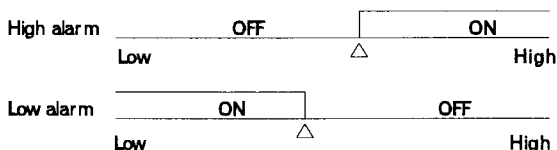

Alarm timer function

This function is used to set the time until the alarm is turned on after the measured-value enters the alarm zone.

Alarm interlock function

This function is used to keep the alarm state even if the measured-value leaves the alarm zone after entering it.

Set data locking

This instrument is provided with the set data lock function to prevent the set-value from being changed by the front key. Use this function to prevent the operator from misoperation after completing the settings.

● Keeping the **MONI/MODE** key pressed for 2 sec moves the instrument to engineer mode. In this mode, press the UP or DOWN key to select the lock/unlock state.

Operating precautions

- Turn on the power after connecting all of the input signal wires, otherwise the instrument judges that an input wire break has occurred.
- No influence is exerted upon the controller for power failure of 50ms or less.

NOTE

- For pressure control, use our PCT-300 (CT-300).

7. DISPLAY AT ERROR OCCURRENCE

● Overscale, Underscale

Measured - value (PV) (Flashing)	Measured - value exceeds the input range.	<div style="border: 1px solid black; padding: 5px;"> ⚠ WARNING In order to prevent electric shock, prior to replacing the sensor, always turn OFF the power. </div>
0000 (Flashing)	Overscale (Measured - value exceeds the high input display range limit.)	
UUUU (Flashing)	Underscale (Measured - value below the low input display range limit.)	Sensor or input lead check

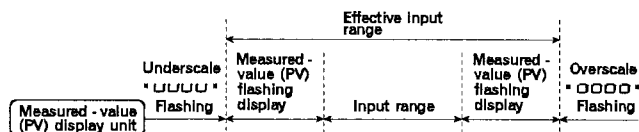

NOTE

The action in case of an input wire break results in the display selected by the break.

However, this does not apply if the input shielded wire (SHD) is disconnected.

● Case by self-diagnosis

If an error is detected during self-diagnosis, "Err" and the details of the error are displayed alternately on the display unit.

Error code	Details	Measures
1	Adjusted data	Turn OFF the power once. If an error occurs after the power is turned ON again, contact your nearest RKC sale office or agent from which you bought the controller.
2 or 4	RAM error	
128	Input error	

● When an error occurs during auto-zero function execution

If the measured-value is not within the auto-zero input range, "Err" and the details of the error are displayed alternately on the display unit.

Error code	Details	Measures
1E	Auto-zero input voltage error	Turn off the power once. Check that the sensor wiring is correct and that the pressure is applied to the sensor, the turn on the power again.

[Example]

If the adjusted data is destroyed and an input error occurs simultaneously

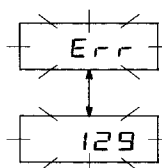

Blinking "Err" and "129" display alternately on the PV display unit.

"129": No. obtained by adding No. corresponding to 1 (adjusted data destroyed) to 128 (input error).

8. REPLACING THE WATERPROOF AND DUSTPROOF RUBBER PACKING

WARNING

- In order to prevent electric shock, always turn off the power supply before replacing the rubber packing.
- In order to prevent electric shock, and instrument failure, always turn off the power supply before pulling out the internal chassis.
- In order to prevent injury or instrument failure, do not touch the internal printed circuit board.

If the waterproof and dustproof rubber packing deteriorates, contact your nearest RKC sales office or agent from which you bought the controller.

Type	Parts code	Remarks
REX-PG410	KF400N-32	For the board
	KD400-35	For the case

■ Replacement of dustproof and waterproof rubber packing

CAUTION

Prior to replacing the rubber packing, first confirm that no water remains, then turn on the power supply. If the water remains, shorting may result.

● For the board

- ① Pull the internal assembly out of the case, then remove the old rubber packing.

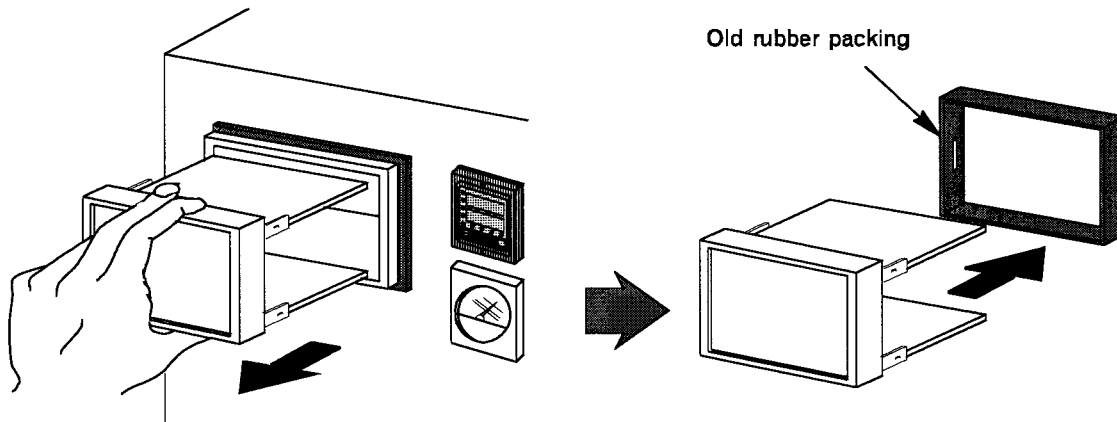

- ② Replace the old rubber packing with a new one, then put the internal chassis in the case.

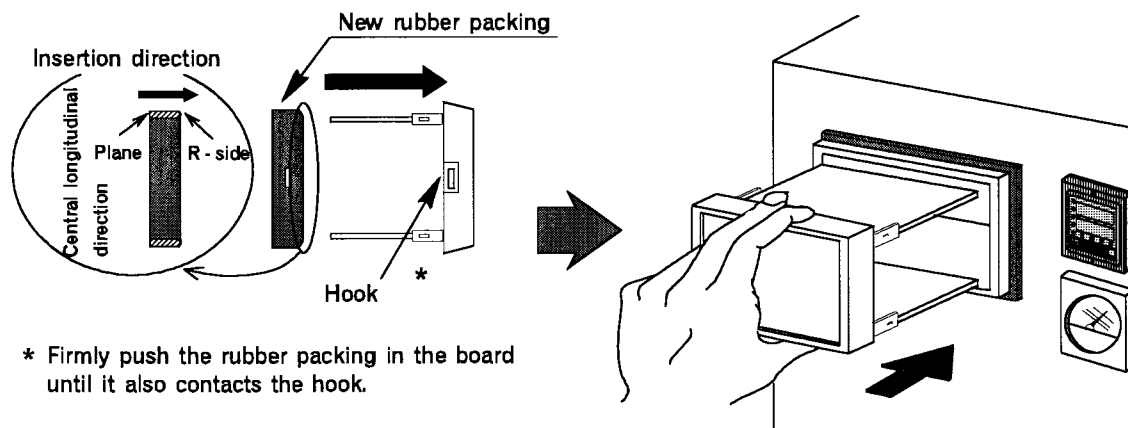

* Firmly push the rubber packing in the board until it also contacts the hook.

● **For the case**

- ① Disconnect the wiring from the rear terminal board and also remove the mounting bracket from the instrument case, then remove the instrument from the panel.

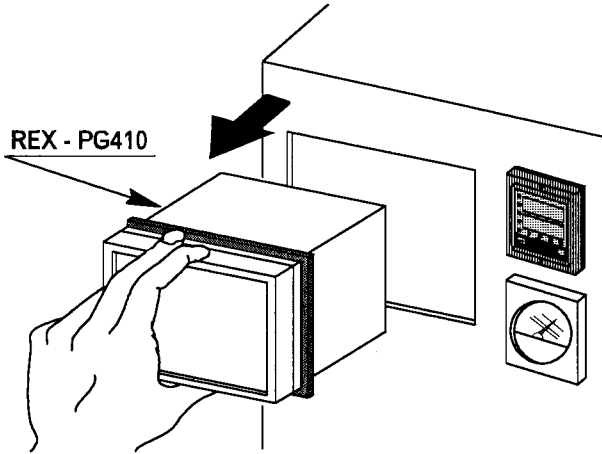

- ② Remove the old packing from this instrument.

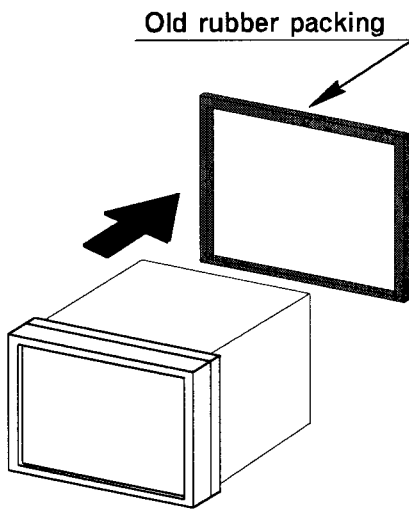

- ③ Firmly push the new rubber packing into the instrument, then re-mount the instrument in the panel.

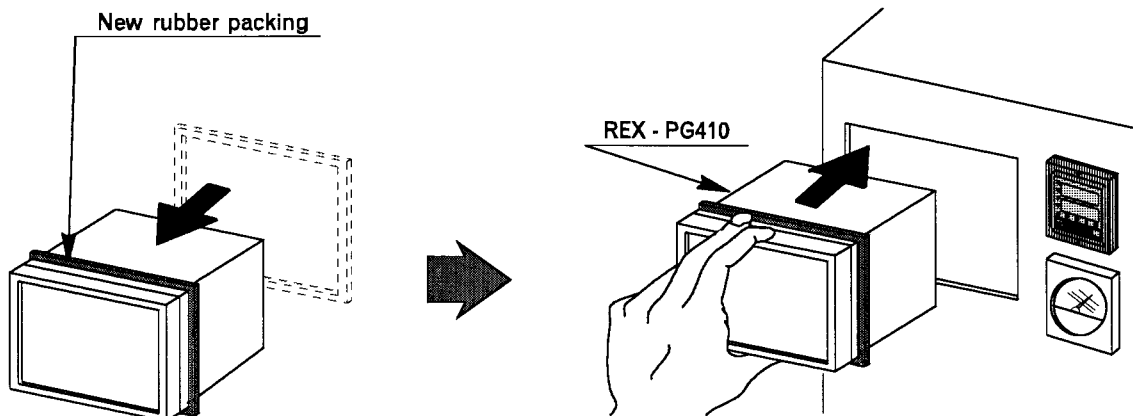

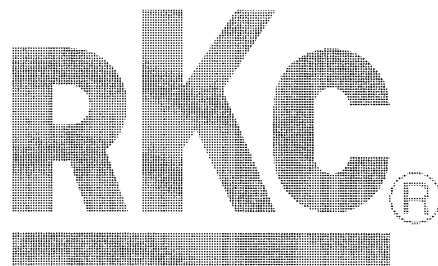

RKC, RKC INSTRUMENT INC.
(RIKA KOGYO CO.,LTD)

HEAD OFFICE: 16 - 6, KUGAHARA 5 - CHOME, OHTA - KU TOKYO 146 JAPAN
PHONE : 03 - 3751 - 9799 (+81 3 3751 9799)
Email : KG100524@niftyserve.or.jp
FAX : 03 - 3751 - 8585 (+81 3 3751 8585)

IM41PG01 - E2

JAN. '98