



REX-F400 REX-F700 REX-F900



General Description

The F series controller provides precise control with high accuracy of 0.1% full scale and short sampling time of 0.25 second. Newly developed and unique logic, Brilliant PID control and Enhanced Autotuning, have been introduced to achieve excellent control. The F series controller is ideal for the application that requires tight tolerance.

Features

- ☆ High accuracy with short sampling time
- ☆ Brilliant PID
- ☆ Enhanced autotuning
- ☆ Multi-memory area : Up to 8 sets of SVs are available

High accuracy with short sampling time

The F series controller provides precise control at high accuracy of 0.1% full scale and short sampling time of 0.25 second. F400 with 1/100°C resolution is also available.

Brilliant PID

Brilliant PID combines stable control with quick response. On the conventional PID control, there is a conflict between control stability and quick response; response to set point change might be compromised when stability is improved, and stability might be compromised when quick response to SV change is achieved. The Brilliant PID retains optimum PID values for stability while you can choose control response types among "Fast", "medium", and "Slow". Please set "Fast" response type when quick response is necessary. "Slow" type is appropriate to avoid overshooting.

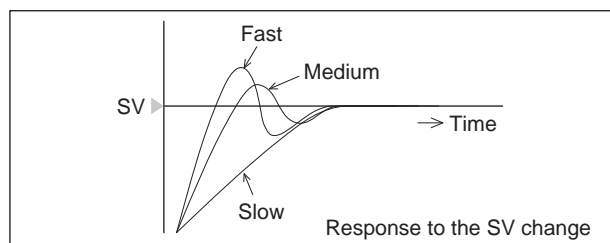

Bar-graph Display

The two 7-segment LED display units show various process data, while the output and the deviation status are displayed on the bar-graph display unit. The resolution is 20 segments for REX-F900 and 10 segments for REX-F400/REX-F700.

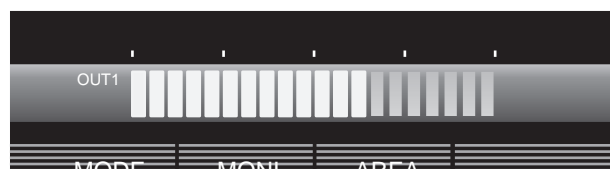

Enhanced autotuning

Enhanced autotuning settles PID values without overshooting. It seeks for PID values by making oscillation artificially below the set point value when AT bias is set up. Newly developed logic is adopted.

[Conventional Autotuning]

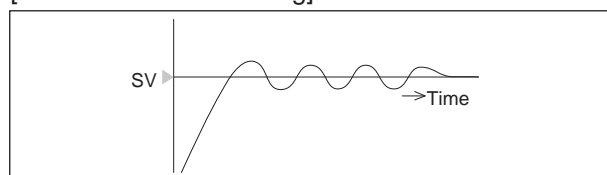

[Enhanced Autotuning]

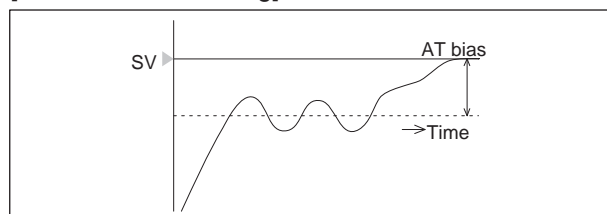

Multi-memory area

The F series has 8 memory areas^{*1}. Each memory area can store the set value, proportional band, integral time, derivative time, response parameter, and alarm set value. You can change all of these values at one time by digital communication, digital input or AREA key on the front panel.

Memory Area 1
SV = 50%, P = 10%, I = 240sec, D = 60sec, Slow,
AL1= 5°C, AL2 = 5°C

Memory area change

Memory Area 2
SV = 80%, P = 20%, I = 360sec, D = 90sec, Slow,
AL1= 10°C, AL2 = 20°C

Digital Temperature Controller **F series**



Specifications

Input

Input

Temperature input group

a) Thermocouple : K, J, R, S, B, E, T, N (JIS/IEC), PLII (NBS)
W5Re/W26Re (ASTM), U, L (DIN)

Influence of external resistance : Approx. 20 μ V/ Ω

Input break action : Up-scale

b) RTD : Pt100 (JIS/IEC), JPt100 (JIS)

Influence of input lead resistance : Approx. less than 20 Ω

Input break action : Up-scale

DC voltage input group

0 to 10mV, 0 to 100mV, 0 to 1V, 0 to 5V, 1 to 5V, 0 to 10V

Input break action : Down-scale (value around zero)

DC current input group

0 to 20mA, 4 to 20mA

Input break action : Down-scale (value around zero)

Sampling time

0.25 sec

PV bias

-5.00 to 5.00% of span

Performance

Measuring accuracy

\pm (0.1% of span + 1 digit)

Cold-junction temperature compensation error

Within $\pm 1.0^\circ\text{C}$ (between 0 and 50°C [32 and 122°F])

•Accuracy is not guaranteed between 0 and 399°C (0 and 800°F) for type B input.

Bar graph display

REX-F900 : 20-dot green LED

REX-F400, F700 : 10-dot green LED

•MV, deviation or POS (valve position) is displayed.

Insulation resistance

More than 20M Ω (500V DC) between input terminals and ground terminals.

More than 20M Ω (500V DC) between power terminals and ground terminals.

Dielectric strength

1000V AC for one minute between input terminals and ground terminals.

1500V AC for one minute between power terminals and ground terminals.

Control

Control method

a) ON/OFF control.

b) Brilliant PID control with enhanced autotuning.

c) Brilliant PID control (heat/cool type)

(Dedicated autotuning function for extruders is available)

d) Position proportioning control.

Memory area

F900, F700 : 8 areas

F400 : 2 areas (8 areas if Z-163 is specified)

Major setting range

Setting range : Same as input range.

Heat-side proportional band : 0.1 to 999.9% of span

(Zero is not setttable)

Cool-side proportional band : 0.1 to 999.9% of span

(Zero is not setttable)

Integral time : 1 to 3600sec. (Zero is not setttable)

Derivative time : 0 to 3600sec. (P + I action when D is 0.)

Deadband/Overlap : -10.0 to 10.0% of span

Control response : Slow, medium, fast

Proportional cycle time : 1 to 100 sec.

Output limiter high : -5.0 to +105.0%

Output limiter low : -5.0 to +105.0%

Output change rate limiter : 0.1 to 100.0%/sec (OFF by setting zero)

Control output

Relay output (OUT1) : Form C contact, 250V AC 3A (resistive load)

Relay output (OUT2) : Form A contact, 250V AC 3A (resistive load)

Voltage pulse output : 0/12V DC

(Load resistance : More than 600 Ω)

Current output : 0 to 20mA, 4 to 20mA DC

(Load resistance : Less than 600 Ω)

Continuous voltage output : 0 to 5V, 0 to 10V, 1 to 5V DC

(Load resistance : More than 1k Ω)

Triac trigger output :

Zero-cross method. Effective ON current

50mA (at 50°C), 70mA (at 25°C)

• Triac trigger output is not available on OUT2 of heat/cool and position proportioning types.

Motor valve control (position proportioning control type only)

Input resistance (feedback resistance) : 135 Ω as standard.

(Other feedback : 100, 200, 500, 1k, 10k Ω)

POS sampling cycle : 1 sec.

Neutral zone : 0.1 to 10.0% (output), resolution 0.1%

Output : Relay output, 250V AC 3A (resistive load)

Form C contact for OPEN and Form A contact

for CLOSE.

Motor rotating speed : Suitable for 20 to 240 sec. (full open to full close)

Alarm

(Optional)

Temperature alarm

a) Number of alarms : 2 points

b) Alarm action : Programmable (process, deviation, FAIL)

c) Alarm delay time : 0 to 600 sec.

d) Alarm differential gap : 0.00 to 10.00% of span

Heater break alarm

a) Number of inputs : 1 point. (For single-phase heater)

b) CT type : CTL-6-P-N(30A), CTL-12-S56-10L-N(100A)

c) Display range : 0.0 to 100.0A

d) Accuracy : \pm 5% of input value or 2A

(whichever is larger)

e) Sampling time : 0.5 sec.

• PV input and CT input are not isolated from each other.

• When heater break alarm (HBA) function is used, remote set point function is not available.

• When control output type is current output or continuous voltage, heater break alarm is not available.

Alarm output

Relay output, Form A contact 250V AC 1A (resistive load)

Options

Remote set value function

a) Remote set value signal (RS input)

DC voltage (Low) : 0 to 10mV, 0 to 100mV, 0 to 1V DC

DC voltage (High) : 0 to 5V, 1 to 5V, 0 to 10V DC

DC current : 0 to 20mA, 4 to 20mA DC

b) Sampling time : 0.5 sec.

• PV input and RS input are not isolated from each other.

External contact input

F900, F700 : 4 points

a) Memory area change : 3 points

b) Mode change : 1 point

F400 : 1 point (memory area or mode change)

Retransmission output (Only for REX-F700 and REX-F900)

a) Number of outputs : 1 point

b) Output signal : 0 to 10mV, 0 to 100mV DC

(Load resistance : More than 20k Ω)

0 to 1V, 0 to 5V, 0 to 10V, 1 to 5V DC

(Load resistance : More than 1k Ω)

0 to 20mA, 4 to 20mA DC

(Load resistance : Less than 600 Ω)

• Output data can be selected among process value, deviation, local set value, SV remote set value, manipulated output value.

Digital communications

- a) Communication method : RS-422A (4-wire), RS-485 (2-wire)
RS-232C (3-wire)
- b) Communication speed : 1200, 2400, 4800, 9600, 19200 BPS
- c) Bit format
 - Start bit : 1
 - Data bit : 7 or 8
 - Parity bit : Without, Odd or Even
 - Stop bit : 1 or 2
- d) Communication code : ASCII(JIS) 7-bit code

General specifications

External Dimensions (W x H x D)

- F400 : 48 x 96 x 100mm
- F700 : 72 x 72 x 100mm
- F900 : 96 x 96 x 100mm

Self-diagnostic function

ROM • RAM check, input value check, CPU power supply monitor, and watchdog timer.

Supply voltage

- a) 90 to 264V AC (Including supply voltage variation)
[Rating : 100 to 240V AC] (50/60Hz common use)
- b) 21.6 to 26.4V AC (Including supply voltage variation)
[Rating : 24V AC] (50/60Hz common use)
- c) 21.6 to 26.4V DC (Ripple rate 10% p-p or less)
[Rating : 24V DC]

Power consumption

- F400 : Less than 12VA (at 264V AC)
- F700 : Less than 13VA (at 264V AC)
- F900 : Less than 15VA (at 264V AC)
- At 24V AC : Less than 8.0VA
- At 24V DC : Less than 350mA

Effect by power failure

A power failure of 50 msec or less will not affect the control action. If power failure of more than 50 msec occurs, controller will restart. HOT or COLD start is selectable.

Operating environments

0 to 50°C [32 to 122°F] , 45 to 85% RH

Memory backup

RAM is backed up by a lithium battery.

Data retaining period

Approx 10 years (depends on storage and operating conditions.)

Net weight

- F400 : Approx. 310g
- F700 : Approx. 350g
- F900 : Approx. 450g

Digital Temperature Controller F series

Model and Suffix Code

Specifications	Model and Suffix Code												
Size	F400 (1/8 DIN) F700 (3/16 DIN) F900 (1/4 DIN)	<input type="checkbox"/>	<input type="checkbox"/>	<input type="checkbox"/>	<input type="checkbox"/>	<input type="checkbox"/>	<input type="checkbox"/>	<input type="checkbox"/>	<input type="checkbox"/>	<input type="checkbox"/>	<input type="checkbox"/>		
Control method	ON/OFF control PID control with AT Heat/cool PID control Heat/cool PID control with AT for extruder (Air cooling type) Heat/cool PID control with AT for extruder (Water cooling type) Position proportional PID	A	F	V	B	W	Y						
Input type	See input range code table	<input type="checkbox"/>											
Scale range	See input range code table		<input type="checkbox"/>										
Control output (OUT1)	Relay output Voltage pulse Triac trigger DC mA, V (Output signal code 4-8)			M	V	G							
Control output (OUT2)	Control method code A, F, Y Relay output Voltage pulse Triac trigger DC mA, V (See output signal code table.)						No code						
Alarm 1	No alarm See alarm code table						N						
Alarm 2	No alarm See alarm code table							N					
Remote set value	Not supplied See signal code table								N				
Contact input	Not supplied Memory area change Auto/Manual selection Remote/Local selection Computer/Local selection (only for F700/F900) Memory area + Auto/Manual (only for F700/F900) Memory area + Remote/Local (only for F700/F900) Memory area + Computer/Local (only for F900)									N	1 2 3 4 5 6 7		
Analog output	Not supplied See signal code table									N	<input type="checkbox"/>		
Digital communications	Not supplied RS-232C RS-422A (4-wire system) RS-485 (2-wire system)										N	1 4 5	
Front panel color	Blue (standard) Black											N	A

Table 1. Combination of control action and output

Action	Output			
	M Relay output	V Voltage pulse	G Triac trigger	4 - 8 DC mA, V
ON/OFF control	OK	OK	OK	N/A
PID control with AT	OK	OK	OK	OK
OUT(1) of heat/cool PID	OK	OK	OK	OK
OUT(2) of heat/cool PID	OK	OK	N/A	OK
Position proportional PID	OK	N/A	N/A	N/A

OK : Available, N/A : Not available

Table 2. Combination of option and type

	F900	F700	F400
Contact input (Memory area)	OK	See note	OK
Analog output	OK	OK	N/A
Computer interface	OK	See note	See note
Position proportional PID	OK	OK	OK

OK : Available, N/A : Not available

Note: Other options are not selectable if this item is specified.

Output signal code table

4	0 - 5V DC	5	0 - 10V DC	6	1 - 5V DC	7	0 - 20mA DC	8	4 - 20mA DC
---	-----------	---	------------	---	-----------	---	-------------	---	-------------

Alarm code table

A	Deviation High	B	Deviation Low	C	Deviation High/Low	D	Deviation band
E	Deviation High (with alarm hold)	F	Deviation Low (with alarm hold)	G	Deviation High/Low (with alarm hold)	H	Process High
J	Process Low	K	Process High (with alarm hold)	L	Process Low (with alarm hold)	M	FAIL
P	HBA (CTL-6-P-N)	S	HBA (CTL-12-S56-10L-N)				

Note :

1. Auto/Manual is not available on thermocouple and RTD input types except control method code Y.
2. No need to specify (*) if no option is required. If any option is supplied, please specify all suffix code.
3. Please use alarm 2 for heater break alarm (HBA).
4. Heater break alarm and remote set point are not available at the same time.
5. CT (current transformer) for heater break alarm is sold separately.
*CTL-6-P-N (0-30A) Through hole ø5.8
*CTL-12-S56-10L-N (0-100A) Through hole ø12

How to specify safety standard (F400, F900 only)

When you specify the models with CE mark-UL/CSA certification, please add the suffix of "/CE" to the model code.

Digital Temperature Controller **F** series

Signal code table

1	0 - 10mV DC	2	0 - 100mV DC	3	0 - 1V DC	4	0 - 5V DC	5	0 - 10V DC
6	1 - 5V DC	7	0 - 20mA DC	8	4 - 20mA DC				

Input range code table

Thermocouple

Input	Code	Range	Input	Code	Range
K	K 08	-199.9 - 300.0°C	S	S 03	0 - 1700°C
	K 09	0.0 - 400.0°C		S A1	0 - 3200°F
	K 10	0.0 - 800.0°C	B	B 03	0 - 1800°C
	K 11	0 - 1300°C		B A3	0 - 3300°F
	K A4	0.0 - 800.0°F	E	E 03	0.0 - 700.0°C
K A5	0 - 2400°F	E 02		0 - 1000°C	
J	J 07	-199.9 - 300.0°C	E	E A3	0 - 1800°F
	J 08	0.0 - 400.0°C		N	N 02
	J 09	0.0 - 800.0°C	N A1		0 - 2300°F
	J 06	0.0 - 1200°F	PLII	A 01	0 - 1300°C
	J A4	0.0 - 700.0°F		A A3	0 - 2300°F
J A5	0 - 2100°F	W5Re	W 03	0 - 2300°C	
T	T 05	-199.9 - 300.0°C	W26Re	W A2	0 - 4200°F
	T 06	0.0 - 400.0°C	U	U 04	0.0 - 600.0°C
	T A6	-199.9 - 400.0°F		U A4	0 - 1100°F
	T A7	0.0 - 700.0°F	L	L 03	0.0 - 400.0°C
R	R 03	0 - 1700°C		L 04	0.0 - 900.0°C
	R A1	0 - 3200°F	L A2	0 - 1600°F	

RTD

Input	Code	Range
JPt100	P 04	-100.0 - 100.0°C
	P 11	-199.9 - 500.0°C
	P B1	-150.0 - 200.0°F
	P B2	-199.9 - 900.0°F
Pt100	D 04	-100.0 - 100.0°C
	D 12	-199.9 - 600.0°C
	D B1	-150.0 - 200.0°F
	D B3	-199.9 - 999.9°F

Voltage and current

Input	Code	Range
0 - 10mV	1 01	0.0 - 100.0 %
0 - 100mV	2 01	0.0 - 100.0 %
0 - 1V	3 01	0.0 - 100.0 %
0 - 5V	4 01	0.0 - 100.0 %
0 - 10V	5 01	0.0 - 100.0 %
1 - 5V	6 01	0.0 - 100.0 %
0 - 20mA	7 01	0.0 - 100.0 %
4 - 20mA	8 01	0.0 - 100.0 %

Supply voltage

100 - 240V AC

24V AC

24V DC

Please specify when ordering.

Digital Temperature Controller F series

External Dimensions and Rear Terminals

Unit : mm

REX-F900

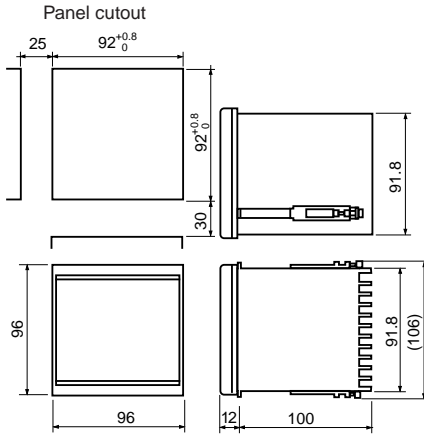
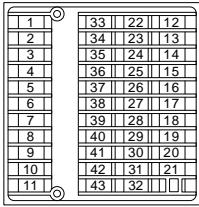

REX-F400

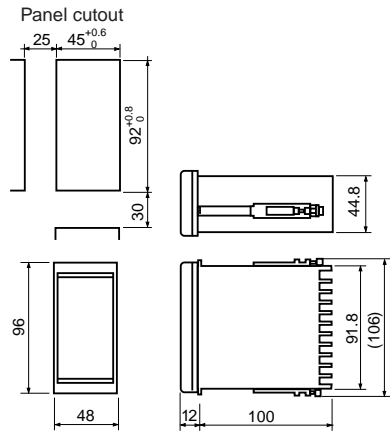

* Terminals 22 to 32 are used only for F900.

No.	Description
1	Ground
2	Power supply
3	Power supply
4	Alarm output
5	Relay contact output
6	Relay contact output
7	Control output (OUT2) (1) Relay contact output (2) Voltage/Current
8	Control output (OUT1) (1) Relay contact output (2) Voltage/Current (3) Triac trigger output
9	Control output (OUT1) (1) Relay contact output (2) Voltage/Current (3) Triac trigger output
10	Control output (OUT1) (1) Relay contact output (2) Voltage/Current (3) Triac trigger output
11	Control output (OUT1) (1) Relay contact output (2) Voltage/Current (3) Triac trigger output

No.	Description
22	Contact input
23	Contact input
24	Contact input
25	Contact input
26	Communications
27	Communications
28	Communications
29	Communications
30	Communications
31	Analog output
32	Analog output

No.	Description
12	Contact input
13	Contact input
14	Feedback resistance input
15	Feedback resistance input
16	Feedback resistance input
17	Current transformer input
18	Remote setting input
19	Sensor input
20	Sensor input
21	Sensor input

REX-F700

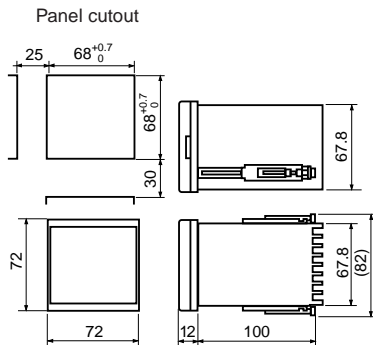
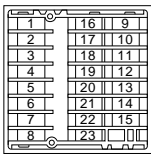

No.	Description
1	Ground
2	Power supply
3	Power supply
4	Control output (OUT2) (1) Relay contact output (2) Voltage/Current
5	Control output (OUT2) (1) Relay contact output (2) Voltage/Current
6	Control output (OUT1) (1) Relay contact output (2) Voltage/Current (3) Triac trigger output
7	Control output (OUT1) (1) Relay contact output (2) Voltage/Current (3) Triac trigger output
8	Control output (OUT1) (1) Relay contact output (2) Voltage/Current (3) Triac trigger output

No.	Description
16	Feedback resistance input
17	Feedback resistance input
18	Feedback resistance input
19	Analog output
20	Analog output
21	Alarm output
22	Relay contact output
23	Relay contact output

No.	Description
9	Mode transfer
10	Contact input
11	Contact input
12	Contact input
13	Current transformer input
14	Remote setting input
15	Remote setting input
16	Sensor input
17	Sensor input
18	Sensor input
19	Sensor input